

1. Features

- Controller of 6 monostable 5A relays
- Operation voltage 16-24V DC
- Maximum current consumption from the bus 100mA
- For DIN rail mounting.
- Dimensions 90x106x53 mm (6 mod)
- Operating of module depends on firmware uploaded into it.
- Schematic and PCB design can be downloaded from hapcan.com site

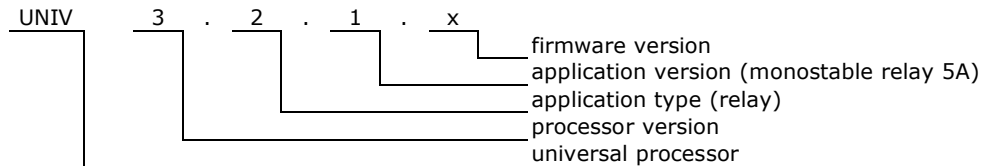

2. Application version



3. Technical data

Bus side

Parameter	Symbol	Value	Unit
Power supply voltage	U_s	16-24	V DC
Current consumption	I_s	6 @24V (144mW) 8 @16V (128mW)	mA
Maximum current consumption (when all relays are on)	I_{smax}	66 @24V (1,64W) 100 @16V (1,56W)	mA
Bus connector type		2x RJ45	

Relay side

Parameter	Symbol	Value	Unit
Coil voltage	U_{COIL}	12	V DC
Coil resistance	R_{COIL}	685	Ω
Nominal contacts current	I_N	5	A
Maximum inrush current	I_{INRUSH}	5	A
Nominal contacts voltage.	U_N	250	V AC
Relay connector type		Terminal Blocks (solid wire 4mm ² , stranded 2,5mm ²)	

4. Hardware

4.1. Schematic

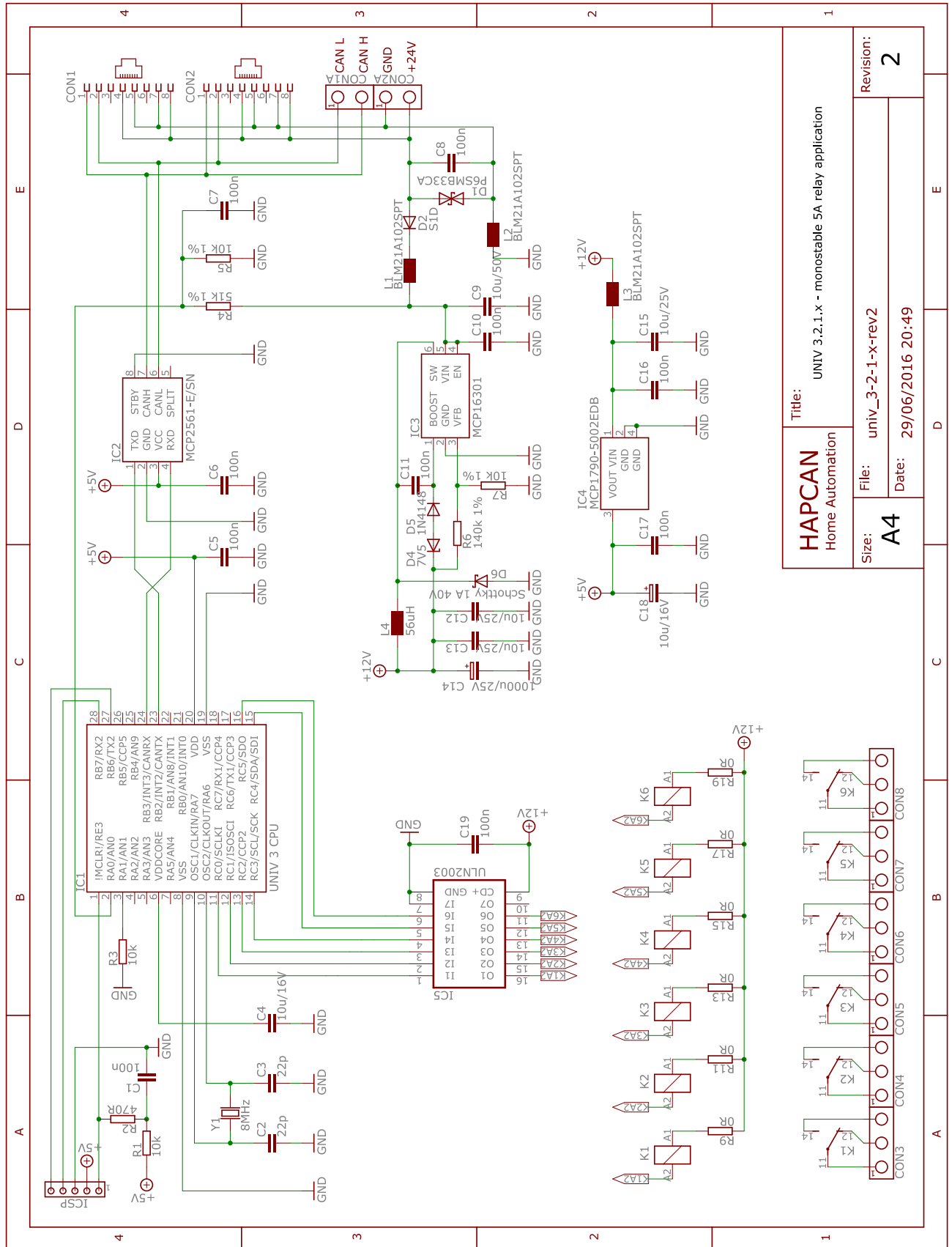

Title: UNIV 3.2.1.x - monostable 5A relay application	
HAPCAN Home Automation	
Size: A4	Revision: 2
File: univ_3-2-1-x-rev2	
Date: 29/06/2016 20:49	

Figure 1. Schematic of monostable relay application UNIV 3.2.3.x

4.2. Wiring

⚠ WARNING. This module must be connected to **one phase** of mains.

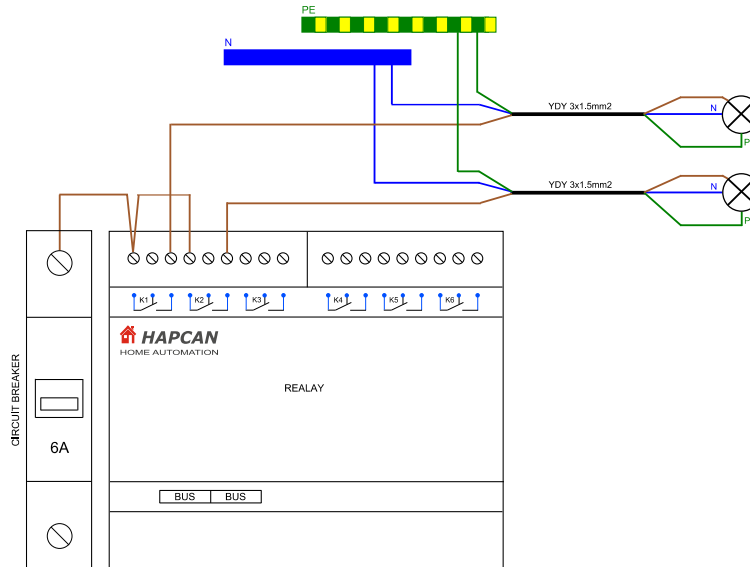
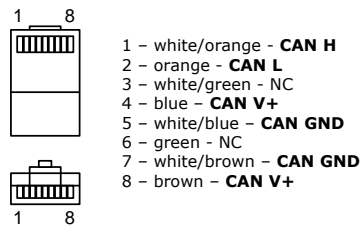

Figure 2. Relay wiring.



Note that if module is first or last on the bus, the terminator (resistor 120 Ohm) must be plugged into one of BUS ports.

Figure 3. RJ45 bus connector wiring.

4.3. PCB assembly schematic

- Printed circuit board *PCB UNIV 3.2.(1-2).x* for UNIV 3.2.1.x module
- PCB dimensions: 103mm x 86.5mm

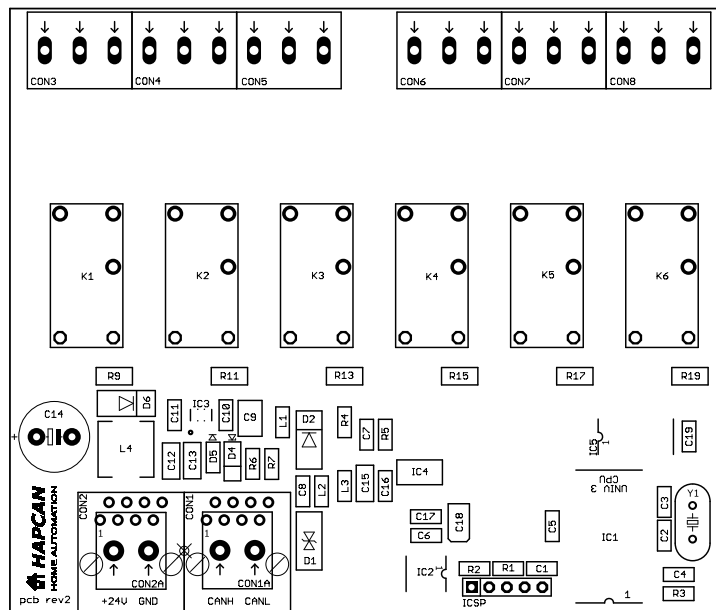

4.4. Components

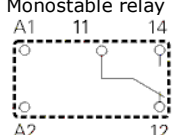
Designator	Quantity	Type	Footprint	Description
C1, C5, C6, C7, C8, C10, C11, C16, C17, C19	10	100nF/50V ±10%	0805	Ceramic capacitor
C2, C3	2	22pF/50V ±10%	0805	Ceramic capacitor
C4	1	10uF/16V ±10%	0805	Ceramic capacitor
C9	1	10uF/50V ±10%	1206, 1210	Ceramic capacitor
C12, C13, C15	3	10uF/25V ±10%	1206	Ceramic capacitor
C14	1	1000uF/25V	ø10, raster 5mm	Electrolytic capacitor tht
C18	1	10uF/16V ±10%	SMA, SMB	Tantalum capacitor
R1, R3	2	10k	0805	Resistor
R2	1	470 Ohm	0805	Resistor
R4	1	51k 1%	0805	Resistor
R5, R7	2	10k 1%	0805	Resistor
R6	1	140k 1%	0805	Resistor
R9, R11, R13, R15, R17, R19	6	0 Ohm	1206	Resistor
L1, L2, L3	3	BLM21A102SPT	0805	Choke Murata
L4	1	DER0705-56	7.6mm x7.6mm	Choke Ferrocere
Y1	1	8MHz	HC49-S	Quartz crystal
D1	1	P6SMB33CA	DO-214	Transil diode
D2	1	100V 1A	DO-214	Rectifying diode
D4	1	Zenera 7V5 0.5W	MiniMELF	Zener diode
D5	1	1N4148	0805	Rectifying diode
D6	1	MBRS140T3G	DO-214	Shottky diode
IC1	1	UNIV 3 CPU	SOIC-28	HAPCAN universal processor
IC2	1	MCP2561-E/SN	SOIC-8	CAN transceiver Microchip
IC3	1	MCP16301T-I/CHY	SOT-23-6	DC/DC converter Microchip
IC4	1	MCP1790-5002EDB	SOT-223	Voltage regulator Microchip
IC5	1	ULN2003	SOIC-16	Darlington transistors arrays
CON1, CON2	2	95501-2881	L18xW15xH11	Connector RJ45 Molex
CON3, CON4, CON5, CON6, CON7, CON8	6	AK700/3-5.0-V-GREEN-BR	L15xW10.5xH19 raster=5mm	Terminal block PTR Messtechnik
K1, K2, K3, K4, K5, K6	6	PE014012 SCHRACK Contacts 5A/250V Coil 12V/17mA	L20xW10xH10	Monostable relay 

4.5. Enclosure

- Gainta D6MG enclosure (6 modules wide)
- Dimensions: 90mm x 58mm x 106mm

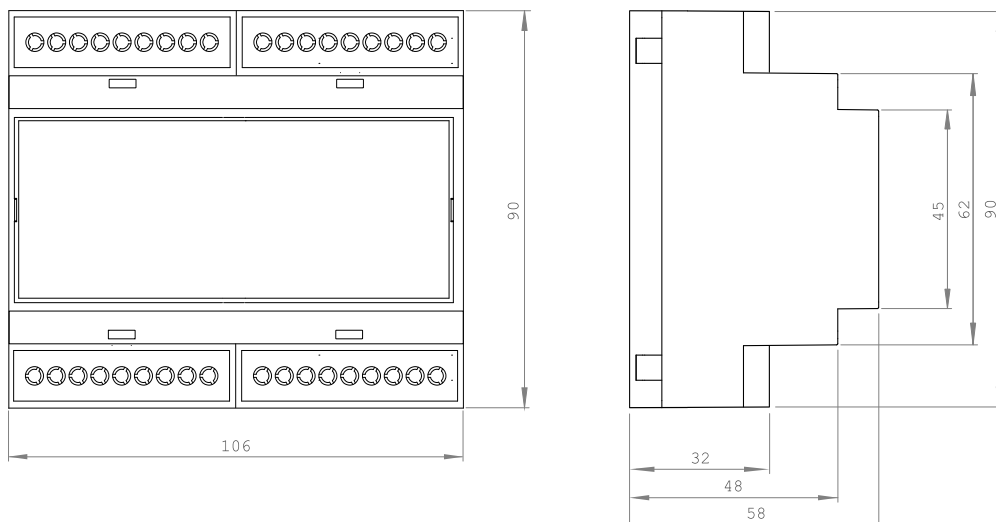

4.6. Mechanical processing

Striped parts must be removed.

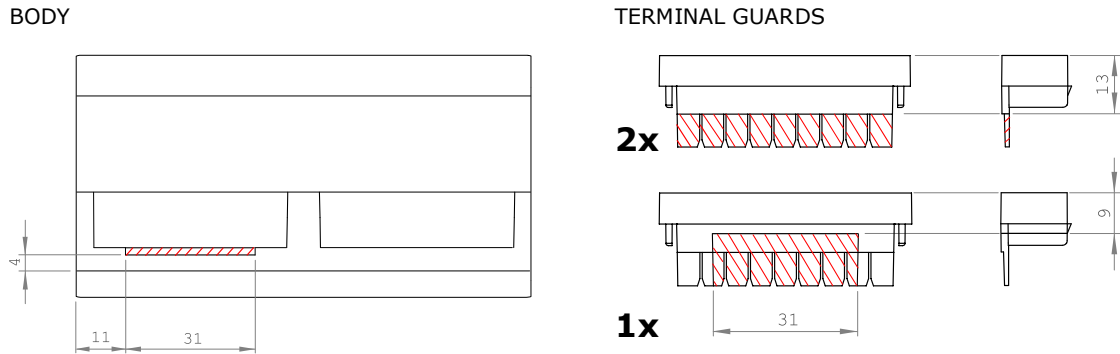

4.7. Label

Editable label version is available at hapcan.com website.

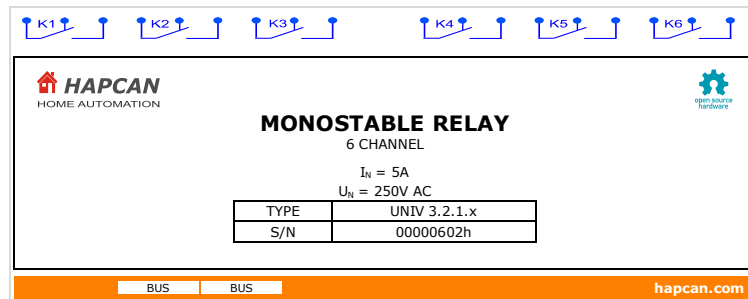

5. Commissioning

5.1. CPU voltage measurement

After verifying the correctness and quality of the soldering, the bus voltage should be connected while measuring the processor voltage. To do this, connect a voltmeter to pins 2 and 3 of the ICSP connector. Processor supply voltage should be about 5V.

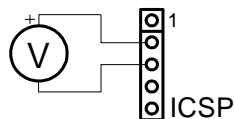

Figure 3. CPU voltage measurement

5.2. Checking the CPU clock

Proper operation of the CPU can be checked by temporarily connecting the LED to pins 3 and 5 of the ICSP connector. When device is powered, the LED should light up four times in the sequence 1 second on - 1 second off - 1 second on. The LED lights up only once for 50ms, if the processor is in programming mode.

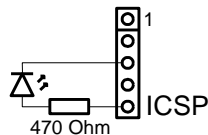

Figure 4. Checking the CPU clock

5.3. Firmware uploading

The device requires a firmware uploading for proper operation. It can be done with HAPCAN Programmer software. Both, firmware and HAPCAN Programmer can be downloaded from hapcan.com website.

6. License



HAPCAN Home Automation Project hardware, Copyright (C) 2016 hapcan.com

This device is free hardware: you can redistribute it and/or modify it under the terms of the GNU General Public License as published by the Free Software Foundation, either version 3 of the License, or (at your option) any later version.

This hardware is distributed in the hope that it will be useful, but WITHOUT ANY WARRANTY; without even the implied warranty of MERCHANTABILITY or FITNESS FOR A PARTICULAR PURPOSE. See the GNU General Public License for more details.

You should have received a copy of the GNU General Public License along with this documentation. If not, see <http://www.gnu.org/licenses/gpl-3.0.html>.

7. Document version

File	Hardware Revision	Description	Date
univ_3-2-1-x_a.pdf	rev1	Original version	June 2014
univ_3-2-1-x_b.pdf	rev2	Power supply has been changed	June 2016