

1. Features

- Controller of 2 monostable 5A relays
- Operation voltage 16-24V
- Current consumption 17mA, maximum 50mA
- For DIN rail mounting.
- Dimensions 90x58x36 mm (2 mod)
- Operating of module depends on firmware uploaded into it.

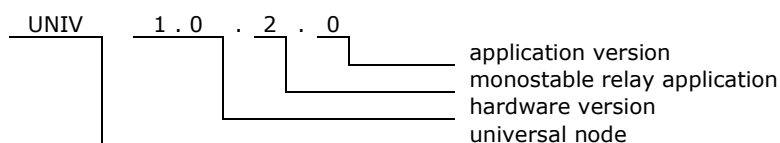

2. Application version



3. Technical data

Bus side

Parameter	Symbol	Value	Unit
Power supply voltage	U_s	16-24V	V
Current consumption (no relay on)	I_s	17	mA
Maximum current consumption (all relays on)	I_{sMAX}	50	mA
Bus connector type	2x RJ45 connectors		

Relay side

Parameter	Symbol	Value	Unit
Relay coil voltage	U_{COIL}	12	V DC
Maximum contacts voltage	U_{MAX}	250 / 30	V AC / V DC
Maximum contacts current with resistive load	I_{MAX}	5	A
Maximum contacts current with inductive load	I_{LMAX}	2	A
Maximum contacts current with capacitive load	I_{CMAX}	0.4	A
Relay connector type	Terminal block (2.5mm ² or 2x1.5mm ²)		

4. Hardware

4.1. Wiring

- ⚠ WARNING 1. This module must be connected only to **one phase** of mains.
- ⚠ WARNING 2. When inductive load connected, use varistors pararelly with relay contacts.

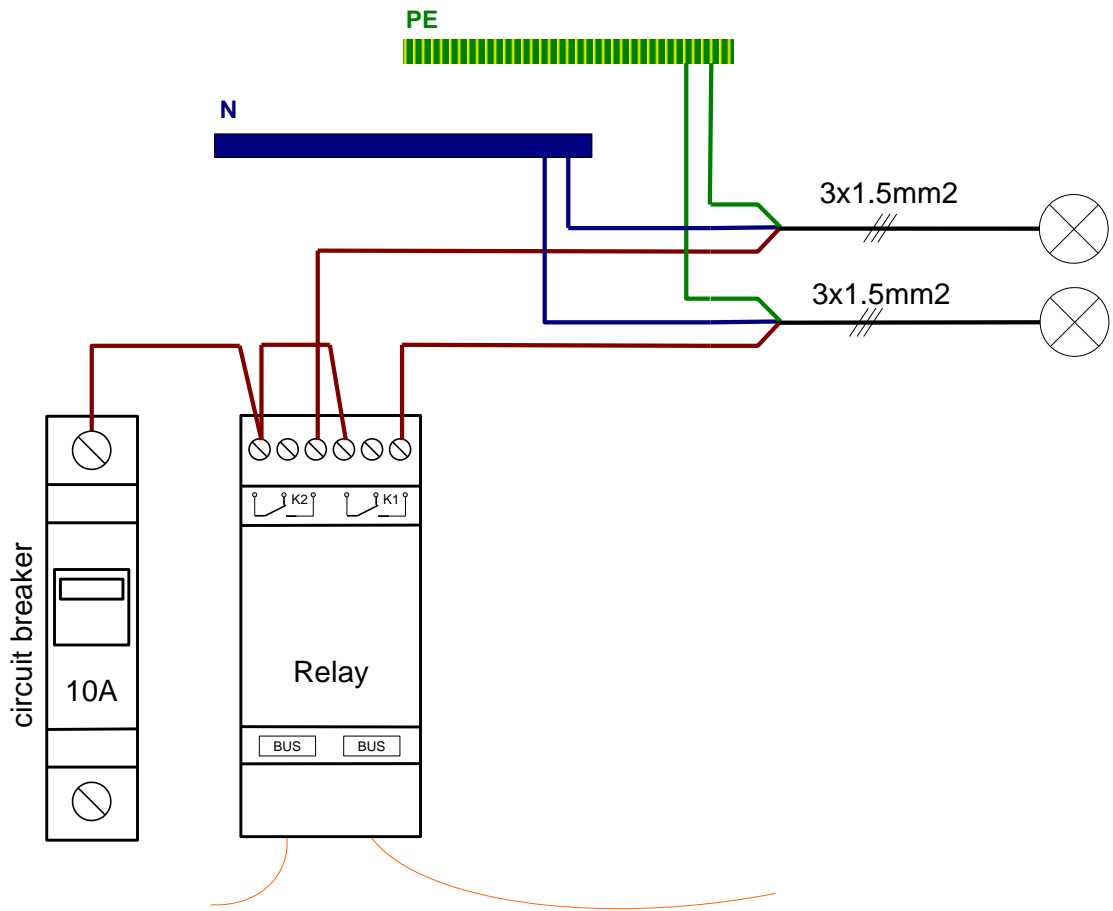

Note that if module is first or last on the bus, the terminator (resistor 120 Ohm) must be plugged into one of BUS ports.

Figure 1. Relay wiring.

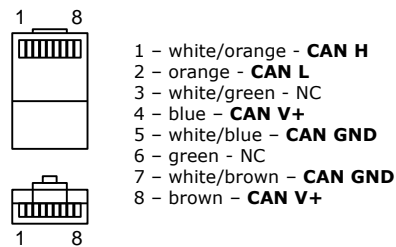
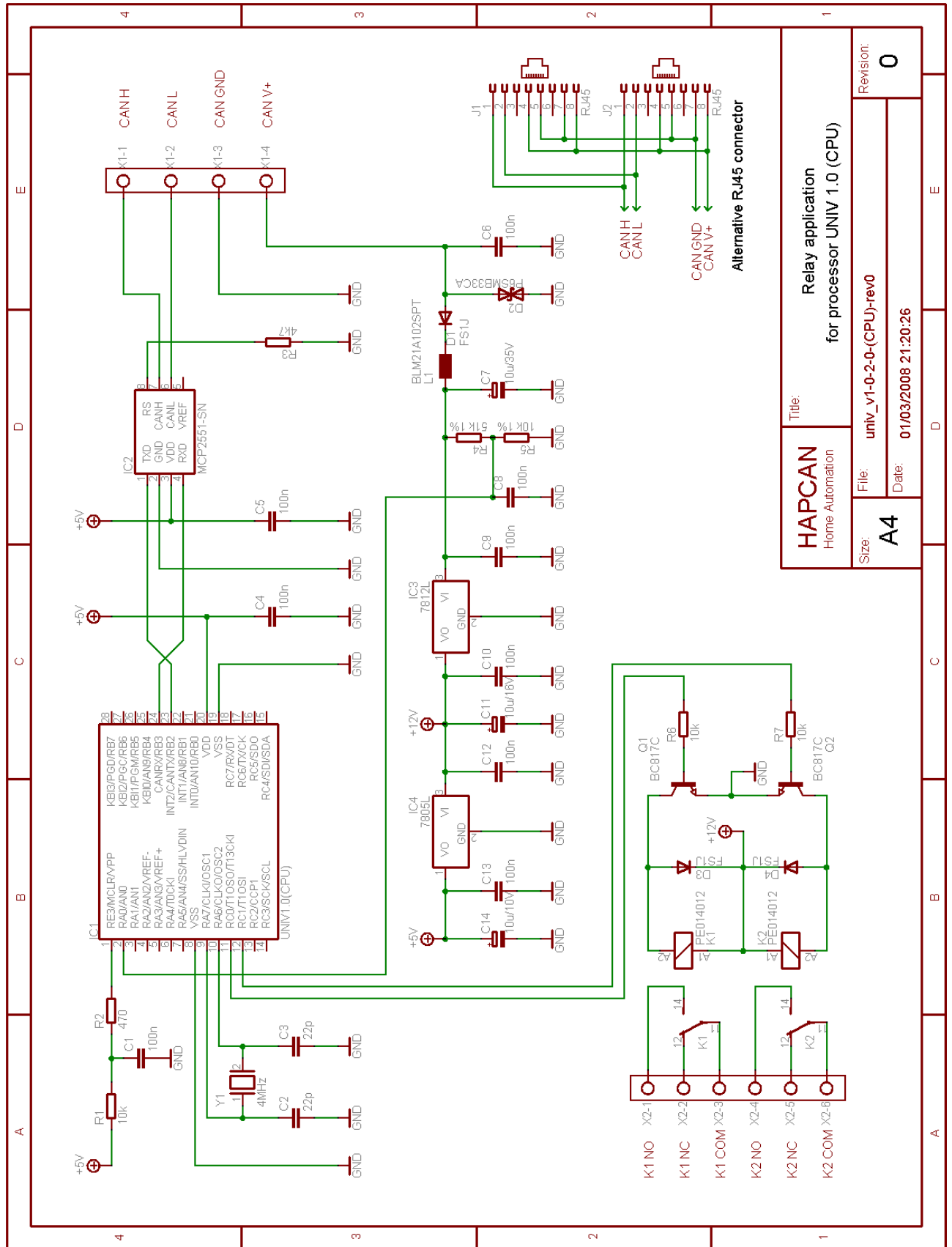

Figure 2. RJ45 bus connector wiring.

4.2. Schematic



HAPCAN Home Automation		Title: Relay application for processor UNIV 1.0 (CPU)	
Size: A4	File: univ_v1-0-2-0-(CPU)-rev0	Date: 01/03/2008 21:20:26	Revision: 0

Figure 3. Schematic of monostable relay application UNIV 1.0.2.0

4.3. Printed Circuit Board

- Printed circuit board for monostable relay application UNIV 1.0.2.0
- PCB dimensions: 86mm x 33mm

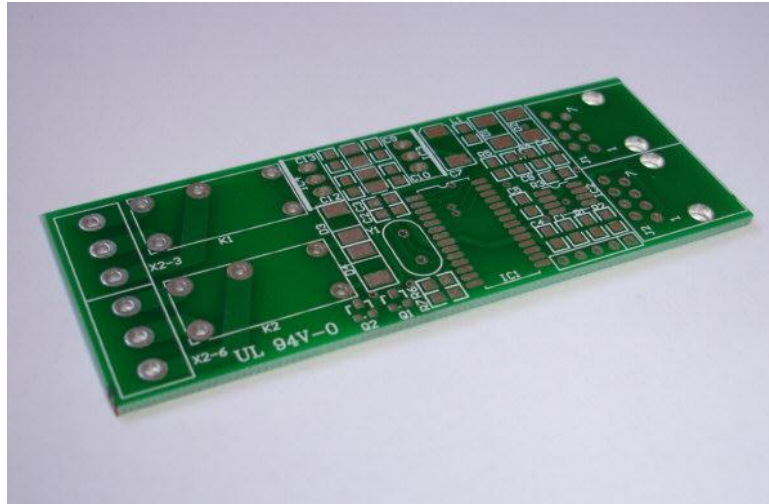

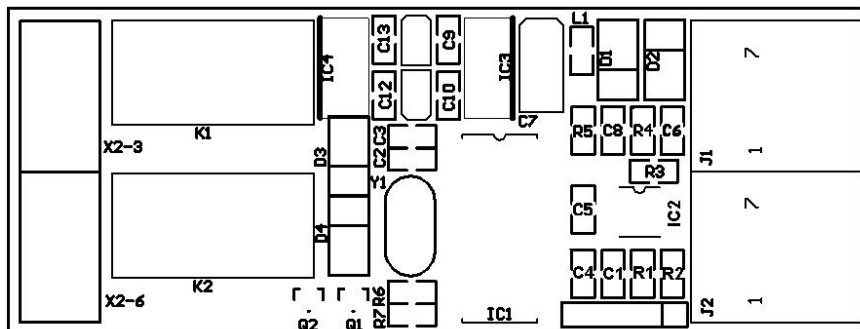

4.3.1. Assembly schematic

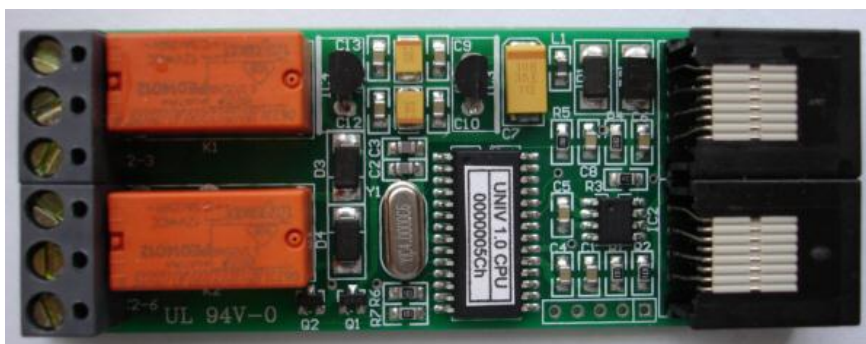

4.3.2. Assembled PCB

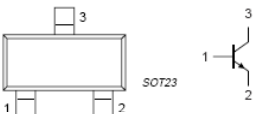
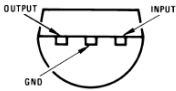

4.3.3. Components

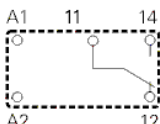
Designator	Type	Footprint	Description
C1, C4, C5, C6, C8, C9, C10, C12, C13	0.1uF	0805	Capacitor
C2, C3	22pF	0805	Capacitor
C7	10uF/35V	SME	Electrolytic Capacitor
C11	10uF/16V	SMB	Electrolytic Capacitor
C14	10uF/10V	SMB	Electrolytic Capacitor
R1, R6, R7	10k	0805	Resistor
R2	470 Ohm	0805	Resistor
R3	4k7	0805	Resistor
R4	51k 1%	0805	Resistor
R5	10k 1%	0805	Resistor
L1	BLM21A102SPT	0805	Choke
Y1	4MHz	HC49-S	Quartz crystal
Q1, Q2	BC817C	sot-23	Transistor NPN 
D2	P6SMB33CA	DO-214	Transil diode
D1, D3, D4	FS1J	DO-214	Diode
IC1	UNIV 1.0 (CPU)	SOIC-28	Processor of HAPCAN universal module
IC2	MCP2551-SN	SOIC-8	CAN Transceiver
IC3	LM7812L	TO-92	Voltage regulator 
IC4	LM7805L	TO-92	Voltage regulator 
K1, K2	PE014012 SCHRACK Contacts 5A/250V Coil 12V/17mA	L20xW10xH10	Relay 
J1, J2	RJ45	L18xW15xH11	Connector
X2	2x ARK3	H=12,5mm aster=5mm	Terminal block

4.4. Enclosure

- Rail mounting enclosure, 2 modules size
- Dimensions: 90mm x 58mm x 36mm

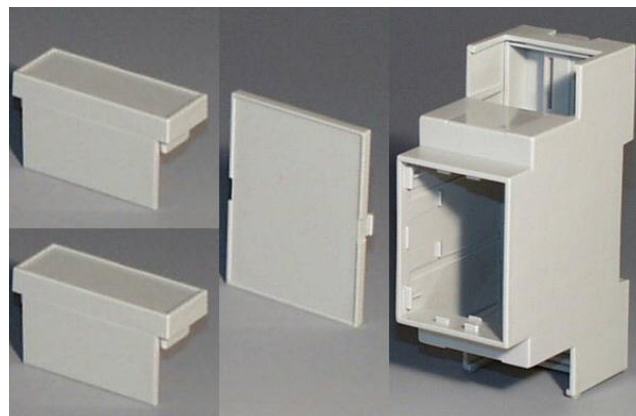

4.4.1. Dimensions

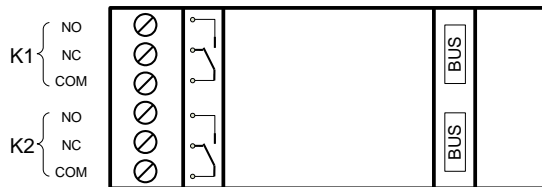
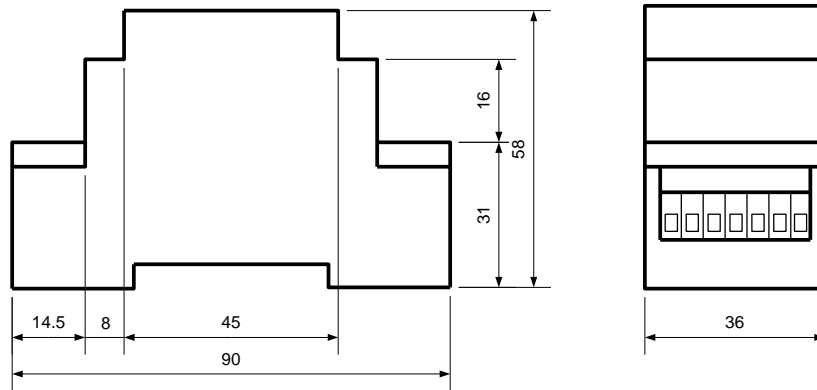

4.4.2. Mechanical processing

4.4.2.1. Main part

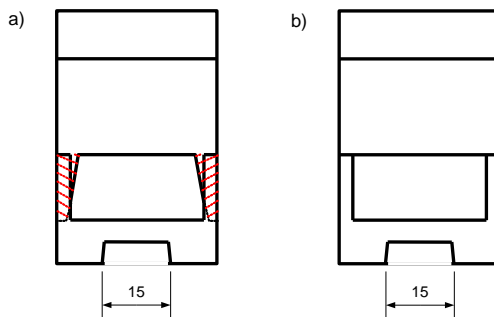

A view from the side, where shown detail is 15mm wide.

Drawing a) shows striped part which must be cut out.

Drawing b) is a view when striped parts have been cut out.

4.4.2.2. Terminal guards

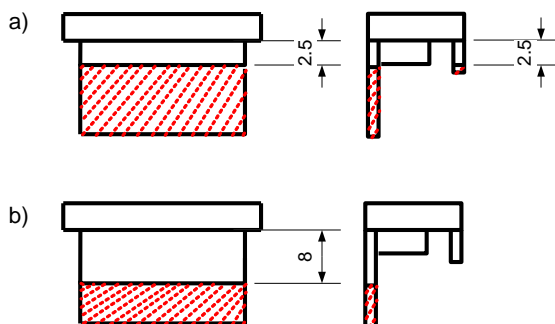

Striped parts must be removed.

Drawing a) shows RJ45 connector guard.

Drawing b) shows terminal block guard.

4.4.2.3. Front panel

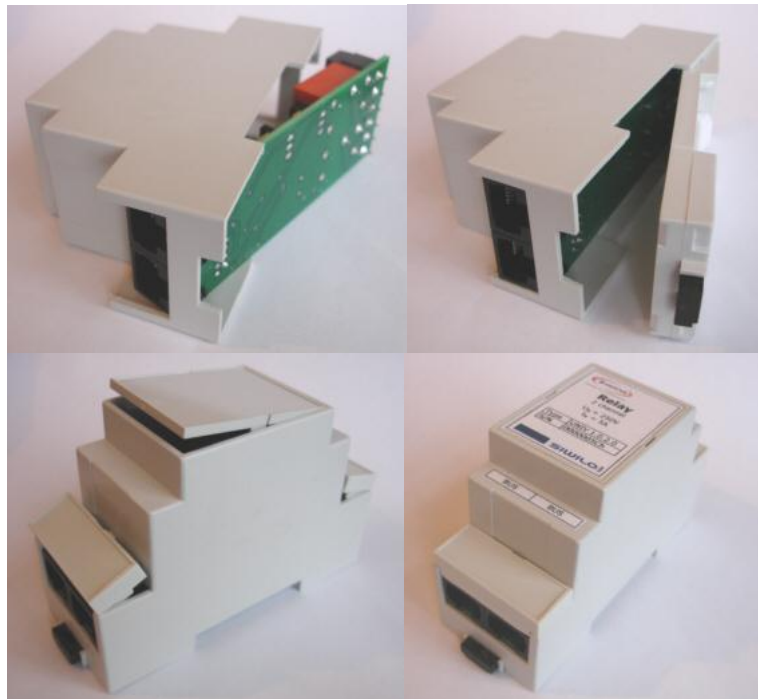

Does not need processing.

4.4.3. Assembling

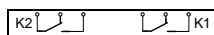

4.4.4. Labels



	
<p>Relay 2 channel $U_N = 250V$ $I_N = 5A$</p>	
Type	UNIV 1.0.2.0
S/N	
	

BUS	BUS
-----	-----

5. Document version

File	Description	Date
univ_v1-0-2-0-pcba.pdf	Original version	April 2008
univ_v1-0-2-0-pcbb.pdf	Updated with schematic	January 2011